

ATC-1204 4-port RS-485 hub

User's Manual

I. General introduction:

ATC-1204 is a RS-485 bus split hub specially designed to meet the demand of RS-485 system in complicated electromagnetic field environment. The product supports maximum 115.2KBPS transmission speed. The RS-485 interface has adopted photoelectric isolation technology to ensure safe and credible data communication, and prevent inducing lightning strike and surge to conversion board and devices. The built in photoelectric isolator and 600W surge protection circuit can offer 3500V isolation voltage, effectively inhibit lightning and ESD and prevent lightning strike and common code interference. It has adopted external switch power supply, safe and credible, quite suitable for outdoor engineering application.

In RS-485 working mode, the adopted identification circuit can detect data direction and switch to control it automatically, easily to solve the time lag of RS-485 during receiving and conversion. The transmission distance of RS-485 interface has exceeded 1200 meters with stable performance. It is a data interface conversion product with superexcellent performance and good price and can be widely applied to freeway charge system, road monitoring system and electric power collection system.

ATC-1204 RS-485 HUB offers star type RS-485 bus connection with each port equipped with short/open circuit protection. With 3500V photoelectric isolation, the user can easily improve RS-485 bus structure, split net segment, and enhance communication credibility. When lightning strike or device malfunction occur, the troubled net segment will be isolated to ensure the

normal function of others, which has greatly enhanced the credibility of existing RS-485 network and effectively shorted network maintaining time. Reasonable use of ATC-1204 RS-485 HUB can help you design a unique and highly credible RS-485 system.

II. Performance parameter

1. Interface feature: interface is compatible with EIA/TIA RS-232C, RS-485 standard
2. Electric interface: RS-232C interface is RJ-45 socket
RS-485 interface is RJ-45 socket
3. Transmission media: twisted-pair cable or shielded cable
4. Working mode: asynchronous half duplex
5. Signal indication: 2 green signal indication lights indicate TXD, RXD and a red one indicates power sequence
6. Isolation: isolation voltage 3500VRMS 500VDC ESD protection
RS-485 interface 600W lightning strike and surge protection on each line.
7. Transmission speed: 115.2K-300 BPS
8. Protecting grade: RS-232 interface \pm 15KV ESD protection
9. Transmission distance: 0-2 kilometers (57600-300BPS)
10. Size: 140mmx130mmx30mm
11. Working environment: -25 $^{\circ}$ C to 55 $^{\circ}$ C, 5% to 95% relative humidity

III. Product panel and signal indication:

There are altogether 7 indication lights on the front panel of ATC-1204 and 6 RJ-45 sockets on the back panel. From the left to the right are respectively port 5, port 4, port 3, port 2, port 1 and Uplink port. The port 5 to port 1 are RS-485 interfaces and Uplink port is a RS-232 interface.



Figure 1 Sketch map of ATC-1204 front panel

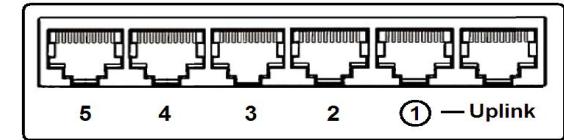

Figure 2 Sketch map of ATC-1204 back panel

The meanings of the ATC-1204 front panel indication lights are as follows:

- PWR — indicates power, red in normal state
- TD — indicates data transmitting, yellow flashes in normal state indicating the data transmitted from UPLINK port or port 1 to port 2-port 5
- RD — indicates data receiving, green flashes in normal state indicating the data transmitted from port 2-port 5 to UPLINK port or port 1
- E1-E4 — port 2-port 5 malfunction alarming light, constant on indicates short circuit or reverse signal occurs to the RS-485 interface device connected to port 2-port 5. The E1 light corresponds with port 2 and E4 light corresponds with port 5. The user can base on the malfunction alarming light to judge malfunctioned port and its connected malfunctioned device.

IV. Electric interface and its definition:

- | | |
|---|----------------------------------|
| RS-232C interface definition (Uplink port) | RS-485 interface (port 1-port 5) |
|---|----------------------------------|

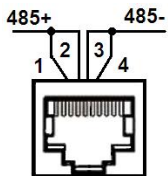
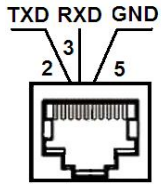

Fig 3 RS-232 interface Fig 4 RS-485 interface

1, RS-232 interface definition: (Uplink port)

RJ-45 connector	definition	Signal direction
2	TXD	OUT
3	RXD	IN
5	GND	-

2. RS-485 interface definition: (port 1-port 5)

RJ-45 connector	RS-485
1, 2	485+
3, 4	485-
7, 8(port 5 only)	Protection grounding

1.The connection map of RS-232 interface RJ-45 plug to DB9 female:

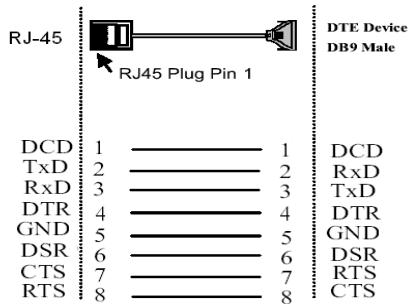

V. Common applications of ATC-1204 4-port RS-485 HUB:

1. PC serial port (RS-232C) to 4 highly credible RS-485 interfaces

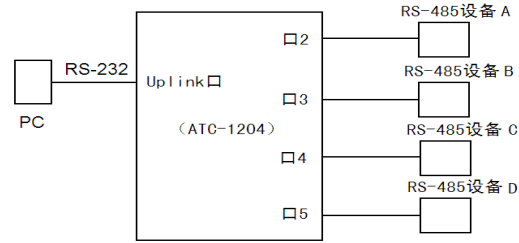

2. Extend the existing RS-485 bus to 4 highly credible RS-485 interfaces

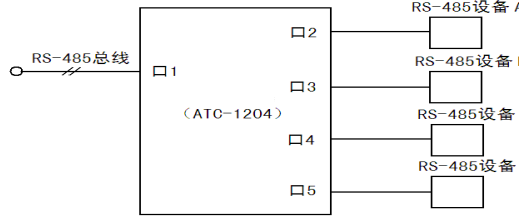

3. PC serial port (RS-232C) to multiple highly credible RS-485 interfaces

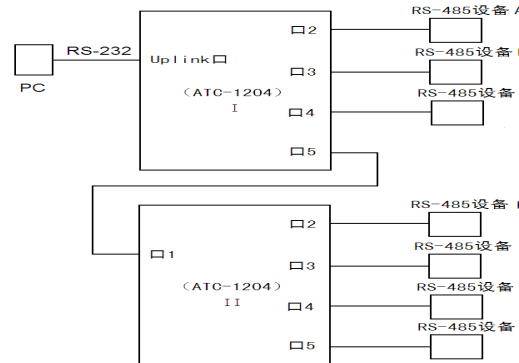

4. Extend the existing RS-485 bus to multiple highly credible RS-485 interfaces

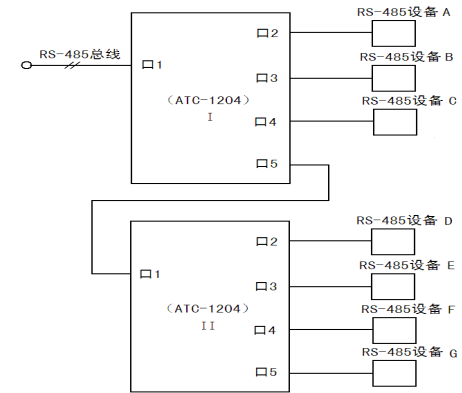

VI. Malfunction alarming and protection of RS-485 port

The malfunction alarming and protection of RS-485 port is an effective method to solve multiple RS-485 devices connection and enhance its credibility. ATC-1204 has 4 slave ports, each port possessing short circuit protection function and capable of working in off mode. When short circuit occurs in any of RS-485 port, it can only affect its own RS-485 bus system and the RS-485 systems connected with other interfaces can work normally. The user can rapidly identify malfunctioned port and its connected malfunctioned device according to malfunction alarming light.

VII. Power supply and lightning protection

ATC-1204 has adopted compact external switch power supply with 5V/1A spec. The user shall not use other power supplies without voltage regulation to avoid product damage! All the RS-485 interfaces of ATC-1204 possesses 400W lightning protection which can effectively inhibits lightning and ESD. The RJ-45 PIN7, 8 in port 5 of ATC-1204 is designed for surge grounding protection. The user shall try to avoid hanging by credible grounding to ensure the safety of communication during operation