



## Ethernet I/O Acquisition Module

A-1812/A-1819/A-1851/A-1855/A-1855S/A-1860/A-1869

### Instruction Manual

- Thank you for purchasing A-18xx Series. We hope you are satisfied with its performance.
- Please read this manual carefully and keep it for future reference.

### Warranty

ATC Co. guarantees that this product meets its published specifications at the time of shipment from the factory. Under proper installation it should work as expected. However, ATC Co. can't guarantee that operation in ATC system is absolutely error-free, or without interruption.

### Warranty Period

Our products are warranted against defects in material and manufacturing for a period of two years from the date of shipment. During the warranty period, ATC is responsible for necessary repairs as long as the product can be proved to be defective. For warranty service or repair this product must be returned to a service facility designated by ATC. Buyer will pay shipping charges to ATC and ATC will pay return shipping charges.

### Excluded Items

This warranty does not include consumptive parts such as batteries, fuses, buttons and relays. Also this warranty does not cover defects caused by improper installation, improper or insufficient maintenance, unauthorized modifications, improper operation, ignorance of environmental specifications, or improper software setting.

### Remarks

- \*No other warranty is expressed or implied, except for the above mentioned.
- \*The remedies provided herein are the buyer's sole and exclusive remedies. ATC shall not be liable for any direct, indirect, special, incidental or consequential damages.

## Include Items

Before using this product, confirm that the following items are contained in the package.

- A-18xx product
- This instruction manual
- Accessory rail

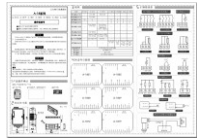

## Dimensions

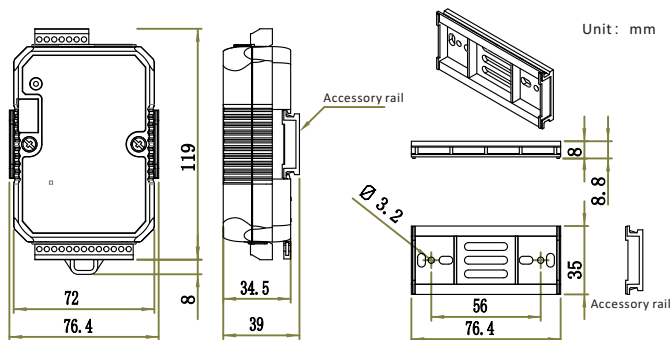

## Specifications

Part number	A-1851	A-1812	A-1819	A-1855	A-1855S	A-1860	A-1869
AI	—	4(16-Bit)	8(16-Bit)	—	—	—	—
AO	—	2(12-Bit)	—	—	—	—	—
DI	16	2	—	8	8	8	—
DO	—	—	—	4	4	4	8
AI Type	—	2*4~20mA, 2*PT-100 /PT-1000 (-200~+600°C)	0/4~20mA, J,K,T,E,R,S,B Thermistor (-270~+1800°C)	—	—	—	—
AO Type	—	0/4~20mA	—	—	—	—	—
AI Impedance	—	Current:100Ω, RTD:10MΩ	Current:100Ω, Vlotage:10MΩ	—	—	—	—
AI/O Accuracy	—	±0.1%/±1%	±0.1%/---	—	—	—	—
DO Continuous Current	—	—	—	8-60VDC /1.75A	10-40VDC /1A	250VAC/7A 30VDC/7A	250VAC /7A 30VDC/7A
Sampling Rate	10 Sample/Second (Total)						
Protocol	MODBUS TCP (Max 7 TCP Sockets)						
Operation Temp	-20~+70°C						
Operation Volt	10~30VDC/24VAC						

## Pin Table

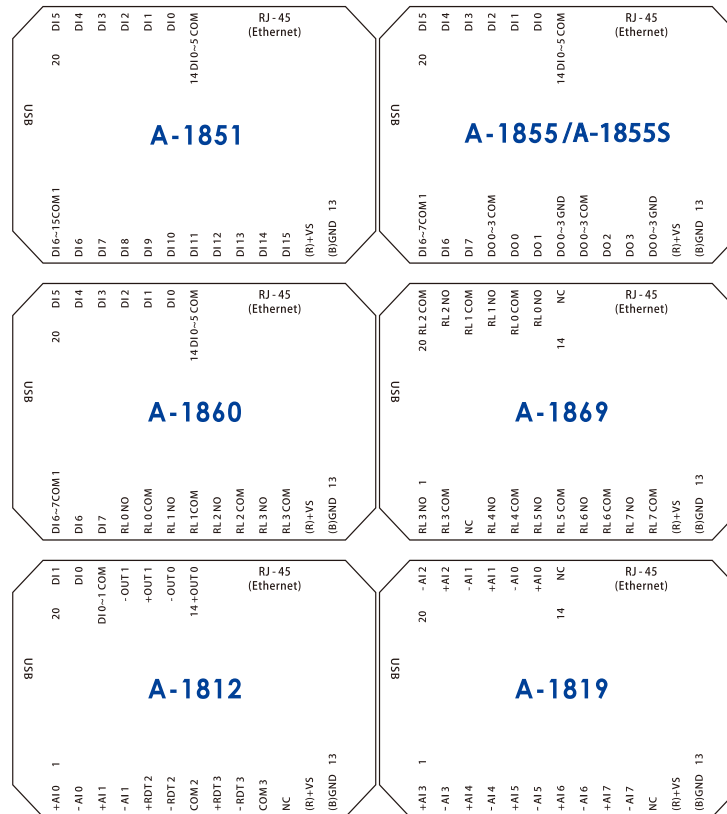

## Wiring Diagrams & Pin Out

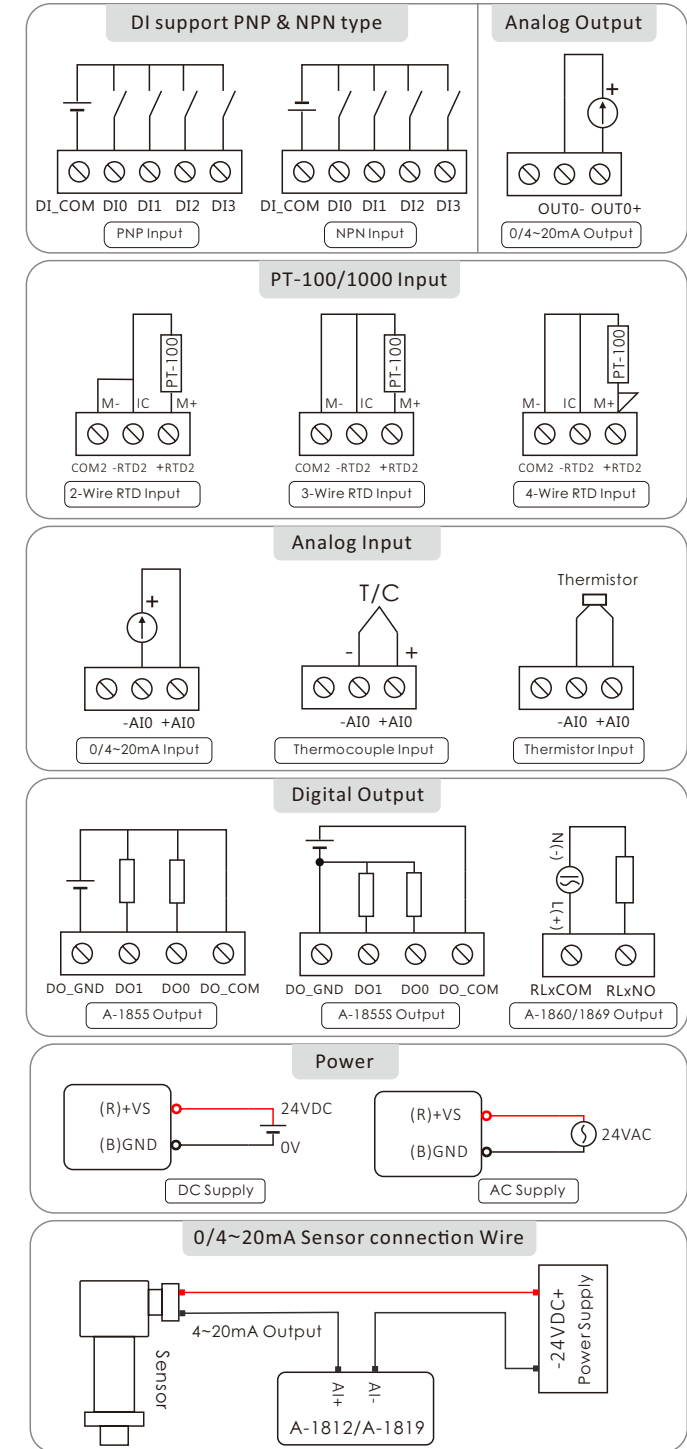

## Parameter Configuration

Please go to the ATC website to download and install the ATC Utility configuration software.  
Website address: www.szatc.com

- Connect the Ethernet I/O module to the LAN or directly to the computer.  
As shown in the figure below:



- Before the module is powered on, turn the switch on the back of the module to Init mode.  
The IP address of the Ethernet I/O module in **Init mode** is **192.168.1.1**  
Please set the computer IP to the same network segment and avoid address conflicts.

- Mode description:  
Init mode is used to modify parameters in ATC Utility software  
Normal mode is the mode used for normal work

- Note:  
If the module is in init mode, it cannot communicate with other devices
- Click to refresh the communication Ethernet port, select the IP of the same network segment as the module, click

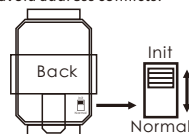

Remarks:  
According to the actual connected module model will search for the corresponding model

IP Address:  
Init Mode: Always 192.168.1.1  
Normal Mode: IP Address set by user  
Note: Click the button to search for A-18xx devices in the LAN

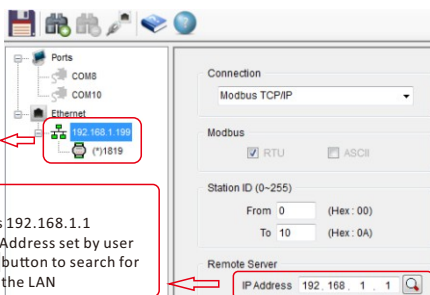

- Ethernet Settings  
Auto Reconnect:  
Network disconnection detection.  
If there is no data communication in the network port within the set time range, the network link will be automatically restarted.

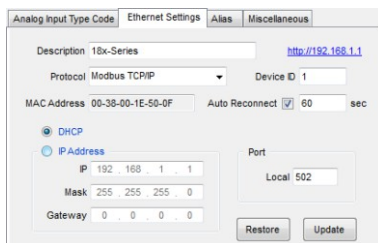

After modifying Ethernet parameters  
Click the [Update] button to save the parameters

## A-1819 Analog Input Type

### Thermocouple

(J:-210~760°C) (K:-270~1,370°C) (T:-270~400°C) (E:-270~1,000°C)  
(R:0~1,750°C) (S:0~1,750°C) (B:0~1,800°C)

### Thermistor

(Thermistor-10K-T2:0~100°C) (Thermistor-10K-T3:0~100°C)  
(Thermistor-6.8K:-10~100°C) (Thermistor-4.7K:-10~100°C)  
(Thermistor-3.3K:-20~100°C) (Thermistor-3K:-20~100°C)  
(Thermistor-2.7K:-20~100°C) (Thermistor-2.252K:-20~100°C)  
(Thermistor-2.1K:-30~100°C) (Thermistor-2K:-30~100°C)  
(Thermistor-1.5K:-40~100°C) (Thermistor-1K:-40~100°C)

## A-1819 Jumper Settings

Each AI channel can be independently configured with input type. Before connecting to the sensor, please open the device shell to see CH0-CH7 on the PCB board according to the actual sensor type, and then set the corresponding jumper (channel 0~1 as an example)



Note: if the analog input type setting of the software is inconsistent with the jumper setting on the circuit board, the measured value will be abnormal.

## Analog Input Type Code Settings

- A-1819 Analog Input Type Code Settings

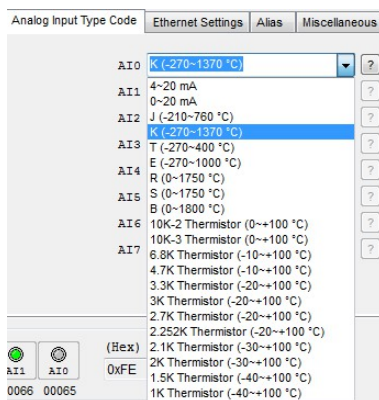

- Set the type of sensor by actually connected.  
When finished, click [update] to save.

- Click button to check the sensor parameter comparison table.

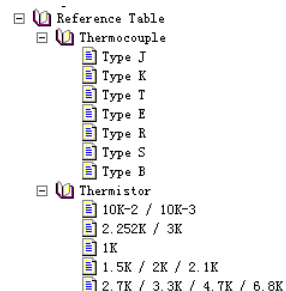

- A-1819 Manual calibration of analog input deviation (miscellaneous)

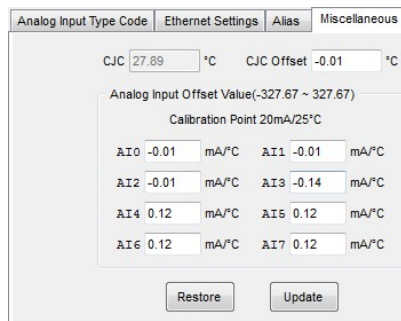

- According to the actual measurement deviation, the parameters can be adjusted by manually.

The default parameter environment for factory adjustment is 20mA / 25°C.

- After adjustment, click the [update] button to save the parameters.

- A-1812 Analog Input Type Code Settings

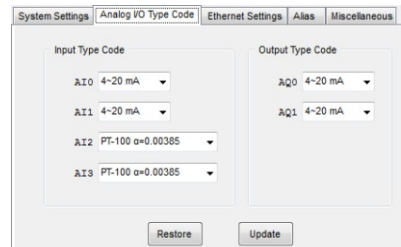

- According to the actual application requirements, set the analog input/output range, PT-100/1000 sensor type. Click the [update] button to save the parameters.

## Modbus Address Mapping

A-1851/A-1855/A-1855S/A-1869/A-1860

Function Code	01/02/05/15	R/W	-
Address 0x	Item	Normal	Init Note
00001 ~ 00016	0 ~ 15 DI Input Signal	R	R
00017 ~ 00032	0 ~ 15 DO Output Value	R/W	R/W
00033 ~ 00048	0 ~ 15 Power On DO Value	R	R/W
00049 ~ 00064	0 ~ 15 Communication Fail Safe Value	R	R/W

A-1812

Function Code	01/02/05/15	R/W	-
Address 0x	Item	Normal	Init Note
00001 ~ 00002	0 ~ 1 DI Input Signal	R	R
00065 ~ 00066	0 ~ 1 Burn-out Signal	R	R 1:Burn-out(4~20mA)
00067 ~ 00068	2 ~ 3 Burn-out Signal	R	R 1:Burn-out
00129 ~ 01152	0 ~ 1023 Auxiliary Memory(M Flag)	R/W	R/W
Function Code	03/04/06/16	R/W	-
Address 4x	Item	Normal	Init Note
40001 ~ 40002	0 ~ 1 Current Input Value	R	R 0~20000:0/4~20mA
40003 ~ 40004	2 ~ 3 Current Input Value	R	R 0~8000:200~+600°C
40017 ~ 40018	0 ~ 1 Current Output Value	R/W	R/W 0~4000:0/4~20mA
40033 ~ 40034	0 ~ 1 Power On Analog Output Value	R	R/W 0~4000:0/4~20mA
40049 ~ 40050	Communication Fail Safe AO Value	R	R/W 0~4000:0/4~20mA

A-1819

Function Code	01/02/05/15	R/W	-
Address 0x	Item	Normal	Init Note
00065 ~ 00072	0 ~ 7 Burn-out Signal	R	R 1:Burn-out
00129 ~ 01152	0 ~ 1023 Auxiliary Memory(M Flag)	R/W	R/W
Function Code	03/04/06/16	R/W	-
Address 4x	Item	Normal	Init Note
40001 ~ 40008	0 ~ 7 Current Input Value	R	R 0~20000:0/4~20mA 0~20700:-270~+1800°C
40097 ~ 40104	0 ~ 7 Current Input Value	R	R 0/4~20:0/4~20mA -270~+1800:-270~+1800°C